

CRYOGENIC GLOBE VALVES

Model 55BS



Features

Actuators

Self and powered actuation options are available and can be designed per customer specific specifications

Packing Design

Available with live load packing and packing rings certified to BAM (Bundes Anstalt für Materialforschung) for oxygen service

Back-Seat Sealing Design

When the valve is stroked open, the specially designed Back-Seat prevents moisture and impurities from leeching into the packing

Extended Bonnet Design

One piece, solid bonnet extension gives added guidance to the spindle and keeps the packing from freezing

Body Construction

One piece, solid body design is available in either cast and forged options and is impact tested to -196°C

Disc Design

Self-aligning contoured disc is designed to prevent moisture and ice from building up inside of the valve

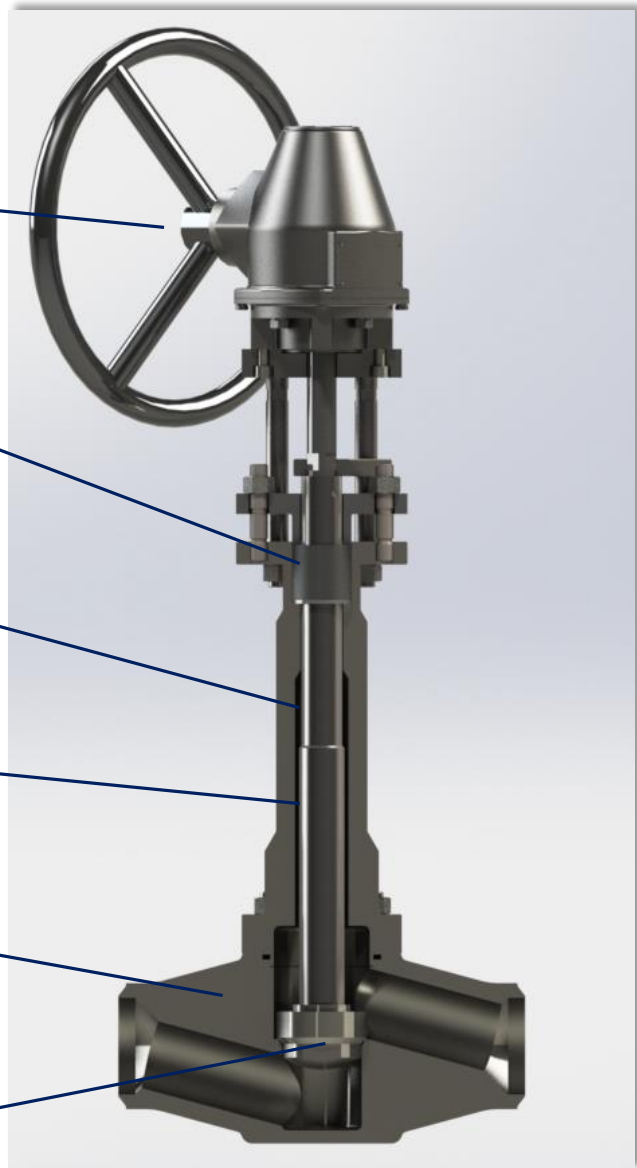

Model 55BS Cryo Globe Valve

SchuF Cryogenic Globe Valves are designed and manufactured for use in virtually every kind of industrial project such as air separation plants, petrochemical plants, steel plants, and oxygen service. Every valve produced at SchuF is individually and specifically designed around the operating conditions and its operational medium.

- Integral seat and self-aligning disc ensure bubble-tight shut-off and extended seal life
- Extended bonnet significantly reduces the thermal conduction between the packing and the medium
- Single piece, solid body and extended bonnet construction provide long lasting service and peace of mind in critical applications
- Copper alloy / Monel® designs are available for gaseous oxygen service
- Valves can be designed with or without copper bearing materials in contact with the atmosphere and medium

Technical Information

Design Features

- Valve sizes ranging from DN32 to DN100
- Pressure Classes: ASME 150 to ASME 1500 / PN 10 to PN 100
- Temperatures: down to -220°C
- Full bore and regulating bores are available
- End connections:
 - Flanged: as per ASME B16.5 for ASME-rated valves and as per EN 1092 for PN-rated valves
 - Welding ends: as per ASME B16.25
 - Other connections: Clamped connectors, upon request
 - Face-to-face: as per API 6D / ASME B16.10 as standard.
 - Others upon request

Design Options

- Copper alloy & Monel construction for oxygen service are available
- Non-Sparking throttling disc option
- Hard-faced sealing surfaces are available
- Materials in accordance with NACE standards are available
- Lockable handwheels are available for valves located in critical or dangerous areas
- EIGA, NASA, NFPA, and DOT compliant designs are available
- Live load graphite packing for high pressure applications

Materials of Construction (typical)

Body and trim parts

- Stainless steels: ASTM A351 CF8M / ASTM A182 F316(L) / ASTM A182 F304(L)
- Duplex steels: UNS S32750 / UNS S31803 / ASTM A995 Gr. 4A or 5A
- Nickel-alloy steels: Monel® / Incoloy® / Inconel® / Hastalloy®
- Copper and brass alloys are also available

Seat materials

- Soft seats: PTFE (with additives), TFM, PEEK
- Tungsten Carbide, Monel, and Inconel
- Gold and silver coatings are also available

Other materials available on request



Model 55BS Cryo Globe Valve

SchuF Worldwide

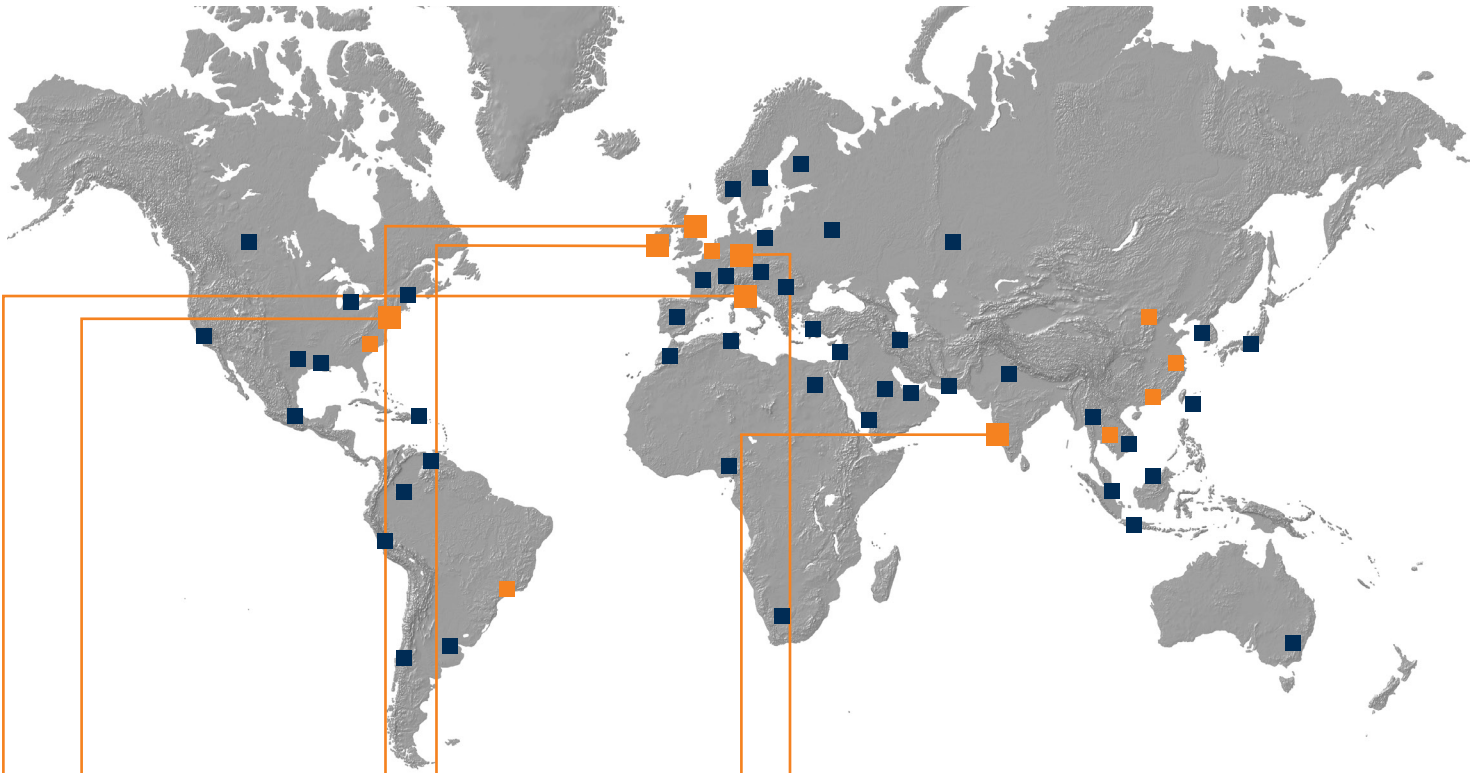

www.schuf.com • www.schuf.de

USA



Fetterolf Corporation
phone: +1 610 584-1500
info@fetterolfvalves.com

SchuF (USA) Inc.
phone: +1 843 8813345
sales@schuf.us

IRELAND



SchuF Valve Technology GmbH
phone: +353 (0)21 4837000
sales@schuf.ie

GERMANY



**SchuF Chemieventile
Vertriebs GmbH & Co.KG**
phone: +49 (0)6198 571100
verkauf@schuf.de

Your Sales Channel:

SchuF Benelux B.V.
phone +31 25 12 34 448
lieke@schuf.nl

Emartins Armaturen – ME
phone: +55 19 98013503
emartins@schuf.com

SchuF South East Asia Pte. Ltd.
phone +31 62062 6664
marius@schuf.nl

SchuF Valves China Ltd.
phone +85 22 86 50 86 1
see@vol.net

ITALY



La Tecnovalvo S.r.l.
phone: +39 023503508
info@latecnovalvo.com

UNITED KINGDOM



SchuF (UK) Ltd.
phone: +44 203 355 2012
sales@schuf.co.uk

INDIA



**SchuF Speciality Valves
India Pvt. Ltd.**
phone: +91 421 2264600
sales@schuf-india.com

Your Local Agent: